

Public Comment Highlights

EPA's Geologic Sequestration Rulemaking



Larry Cole

SECARB 4th Annual Stakeholder's Briefing
March 3, 2009 – Atlanta, Georgia

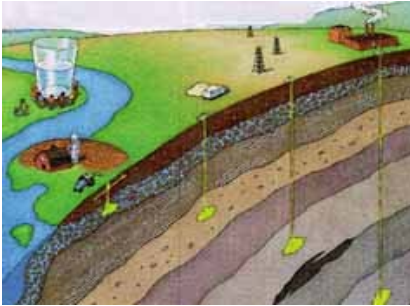

UIC Program Background: *Authority*

- Authority to regulate GS is provided under the Safe Drinking Water Act (SDWA)
 - SDWA requires federal regulations for protection of Underground Sources of Drinking Water (USDWs)
 - Regulations define USDW:
 - Any aquifer or portion of an aquifer that contains water that is less than 10,000 PPM total dissolved solids or contains a volume of water such that it is a present, or viable future source for a Public Water Supply System
- UIC Program regulates underground injection of *all fluids* – liquid, gas, or slurry
 - Designation as a commodity does not change SDWA applicability
 - Some natural gas (hydrocarbon) storage, oil & gas production, and some hydraulic fracturing fluids are exempted
- Existing UIC program provides a regulatory framework for the Geologic Sequestration of CO₂

UIC Program: *Scope*

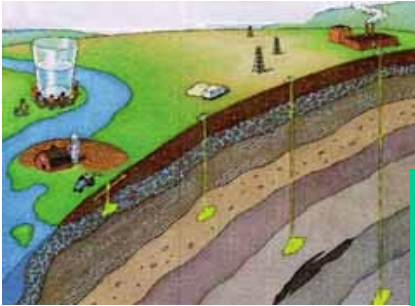

CO₂ Capture and Transport

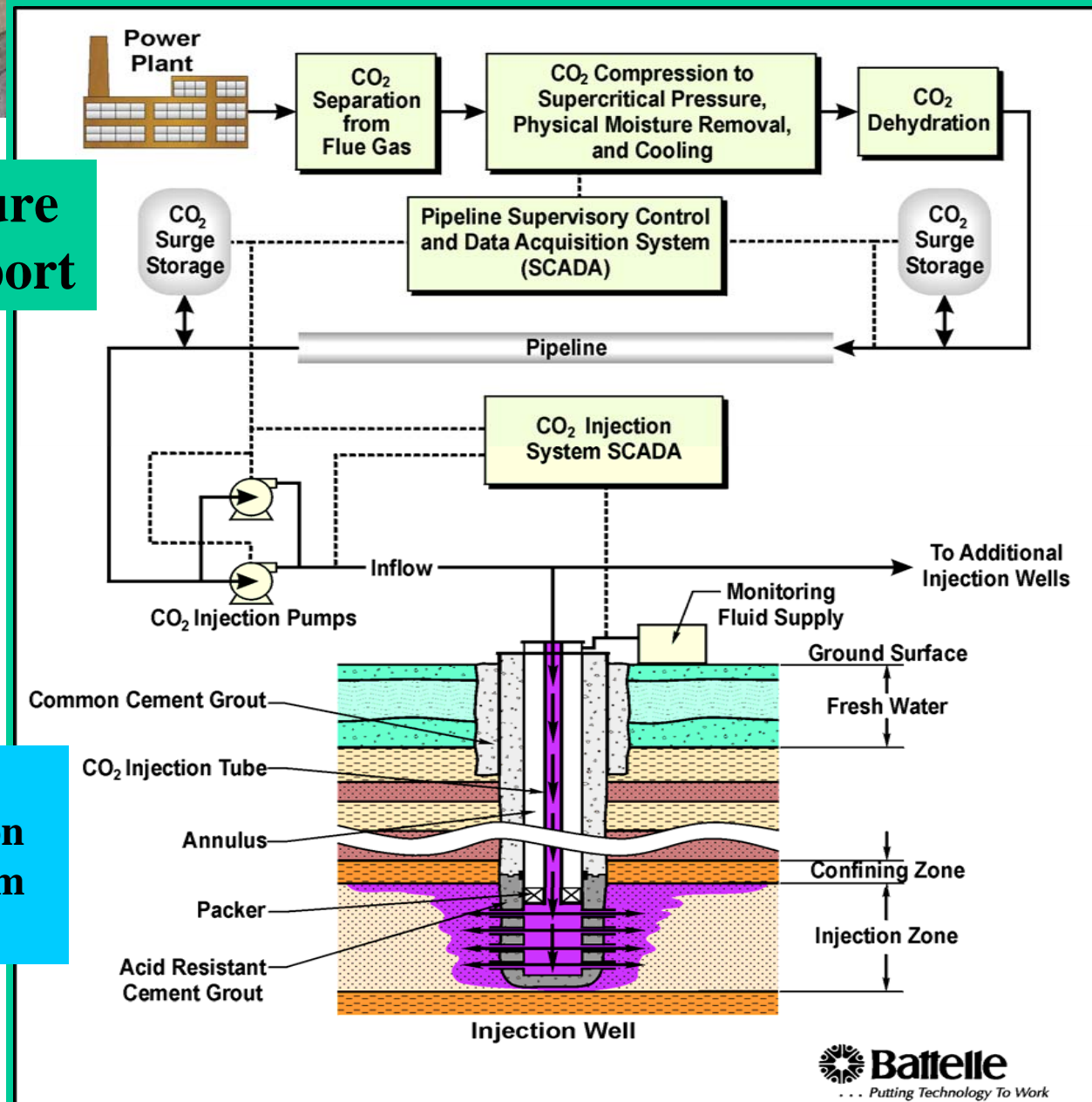

Geologic Sequestration UIC Program Scope



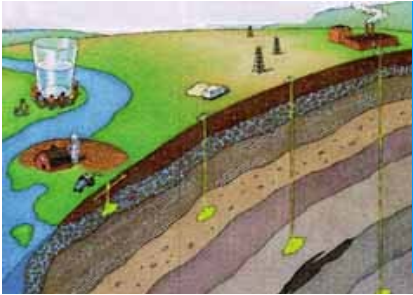

Comment Schedule Review

- Proposal Published: July 25, 2008
- Two Public Hearings:
 - September 30, 2008: Chicago, IL
 - October 2, 2008: Denver, CO
- Comment Period End Date: November 24, 2008
- Comment Period Extension: December 24, 2008

- 365 public submissions
- 151 unique comments



Comment Topics

- Conversion from Class II (Oil and Gas) to Class VI
- Primacy, State Funding, and Expertise
- Injection Depth and Related Topics
- Post-Injection Site Care Timeframe and Closure
- CO₂ Stream Characterization
- Financial Responsibility and Liability Requirements
- Public Participation, Involvement, and Perception
- EPA Statutory Authority Coverage

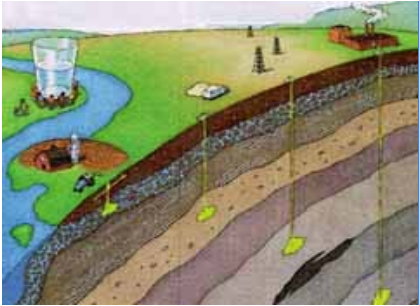

Comment Synopsis

- Conversion from Class II (Oil and Gas) to Class VI
 - New requirements are not necessary
 - By regulation clarify the distinction between Class II and Class VI operations
- Primacy
 - Allow separate primacy for Class VI wells
 - Provide flexibility to permitting authorities
- State Funding
 - UIC programs are not adequately funded to support current well classes
 - Class VI wells will need more funding
- State and Federal Expertise
 - There is insufficient technical capacity, experience, or funding to address GS projects, ensure USDW protection and GS success



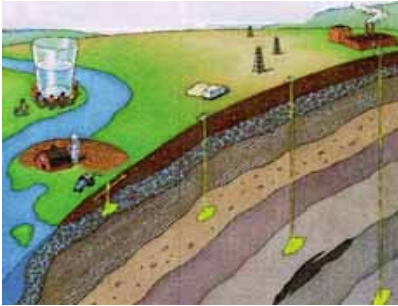

Comment Synopsis

- Injection Depth and Related Topics
 - Do not allow injection above the lowermost USDW *vs.* Allow injection above the lowermost USDW either universally or under specific geologic circumstances
 - Do not establish a minimum injection depth *vs.* Establishing a minimum injection depth based on site specific criteria
 - Do not allow aquifer exemptions for Class VI wells *vs.* Allow aquifer exemptions for Class VI wells either under current or modified criteria
 - Prohibit injection into coal seams, basalts, salt domes *vs.* Allow injection into all formations regardless of type/depth

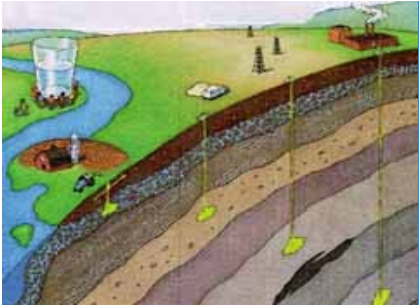

Comment Synopsis

- Post-Injection Site Care Timeframe and Closure
 - The timeframe should be more than 50 years
 - There should not be a fixed timeframe
 - 50 years is “arbitrary” and excessive
 - 50 years with flexibility is supported (by multiple organizations) and is a good “default”
 - The Agency should develop a performance standard to replace a fixed timeframe

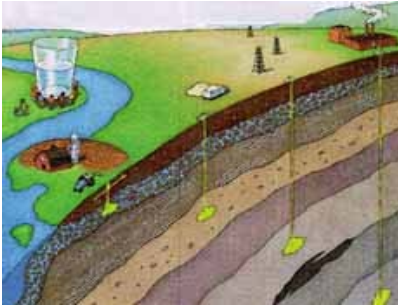

Comment Synopsis

- CO₂ Stream Characterization
 - EPA should not allow injection of hazardous constituents (e.g., CO₂ impurities) through Class VI wells
 - Specificity is requested regarding the purity of CO₂
 - More clarity is needed about *when* the determination is made about whether the CO₂ is a RCRA hazardous waste or not (How do you make this determination?)
 - Carbon dioxide should not be classified as a hazardous waste and does not warrant treatment more stringent than Class I Hazardous wells receive
 - Class VI wells should be given a RCRA exemption/the rule needs more clarity regarding RCRA requirements

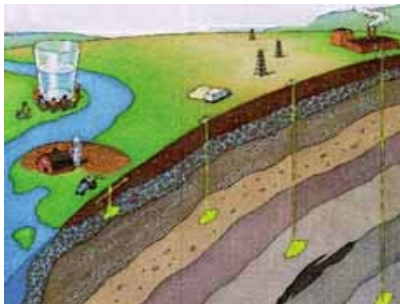

Comment Synopsis

- Financial Responsibility and Liability Requirements
 - Include specific language for FR requirements in the rule
 - Self-insurance should be an option vs. self-insurance should not be an option
 - A Federal/Industry partnership may be useful in addressing liability (rather than it resting with the owner/operator)
 - EPA should consider the fact that the final rule will “send a message” to the financial world about CCS (e.g., the benefits and risks)
 - EPA should address compensation for degradation of private water supplies
 - What will EPA do after 50 years/site closure if there is groundwater contamination?
 - Limit CERCLA liability (in permit)

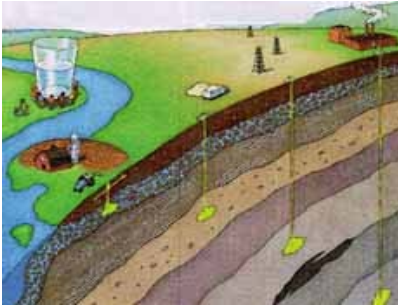

Comment Synopsis

- Public Participation, Involvement, and Perception
 - Need to engage the public early in the GS project development process (e.g., during discussions about siting; permitting; etc.)
 - Need to engage *specific parties* in the GS project development process (e.g., local governments, utilities, citizens and property owners, private well owners)
 - Need to raise national awareness about GS technology, what it is, and what role it would play in climate change mitigation
 - Need to be aware of public perception of GS and ensure that the requirements do not stigmatize GS and “undermine public confidence in the UIC program”

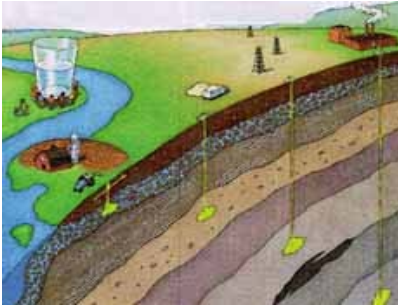

Comment Synopsis

- EPA Statutory Authorities Coverage
 - RCRA/CERCLA Authorities
 - Clean Air Act Authority
 - In conjunction with State Laws (e.g., pore space issues)
- Climate Change
 - EPA should have a comprehensive approach to Climate Change and not a “piecemeal approach” through various program offices, statutes, agencies and departments
 - This issue is too important to ignore, EPA should act quickly to finalize the rule

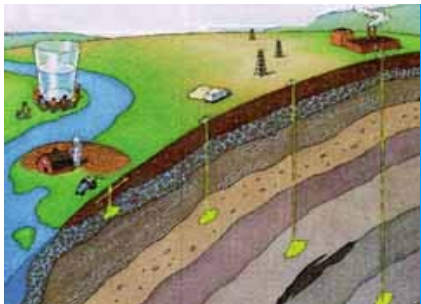

Anticipated Next Steps for GS Rulemaking

Activity	Milestone
Workgroup Kickoff	January 2009
Workgroup Conference Calls	Monthly (Jan – Sept 2009)
Determine Need for NODA	February 2009
OMB Review of NODA	June 2009
Signature and Publication of NODA	November 2009
Public Comment Period for NODA	November – January 2010
OMB Review of Final Rule (without NODA)	Fall 2010
Final Rule Publication (without NODA)	Late 2010
Final Rule Publication (with NODA)	Early 2011

